

# American Trucking Association

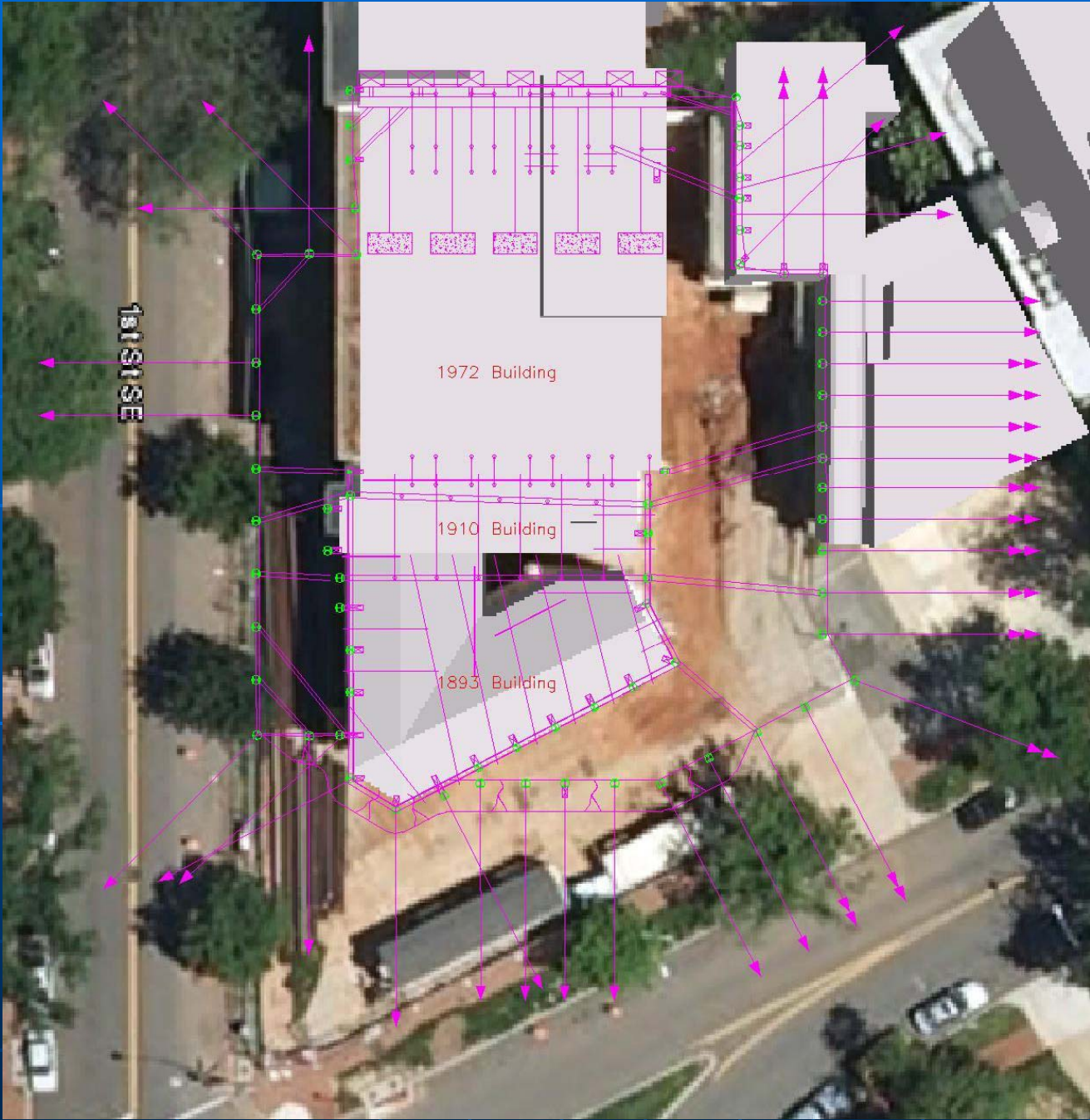

Schnabel  
FOUNDATION COMPANY





- temporary SOE
- 35 ft (10.5 m) excavation depth to allow for a construction of a two level parking garage
  
- 58 micropiles
- 7 underpinning pits
- 21 bracket piles
- approximately 100 needle beams/braces

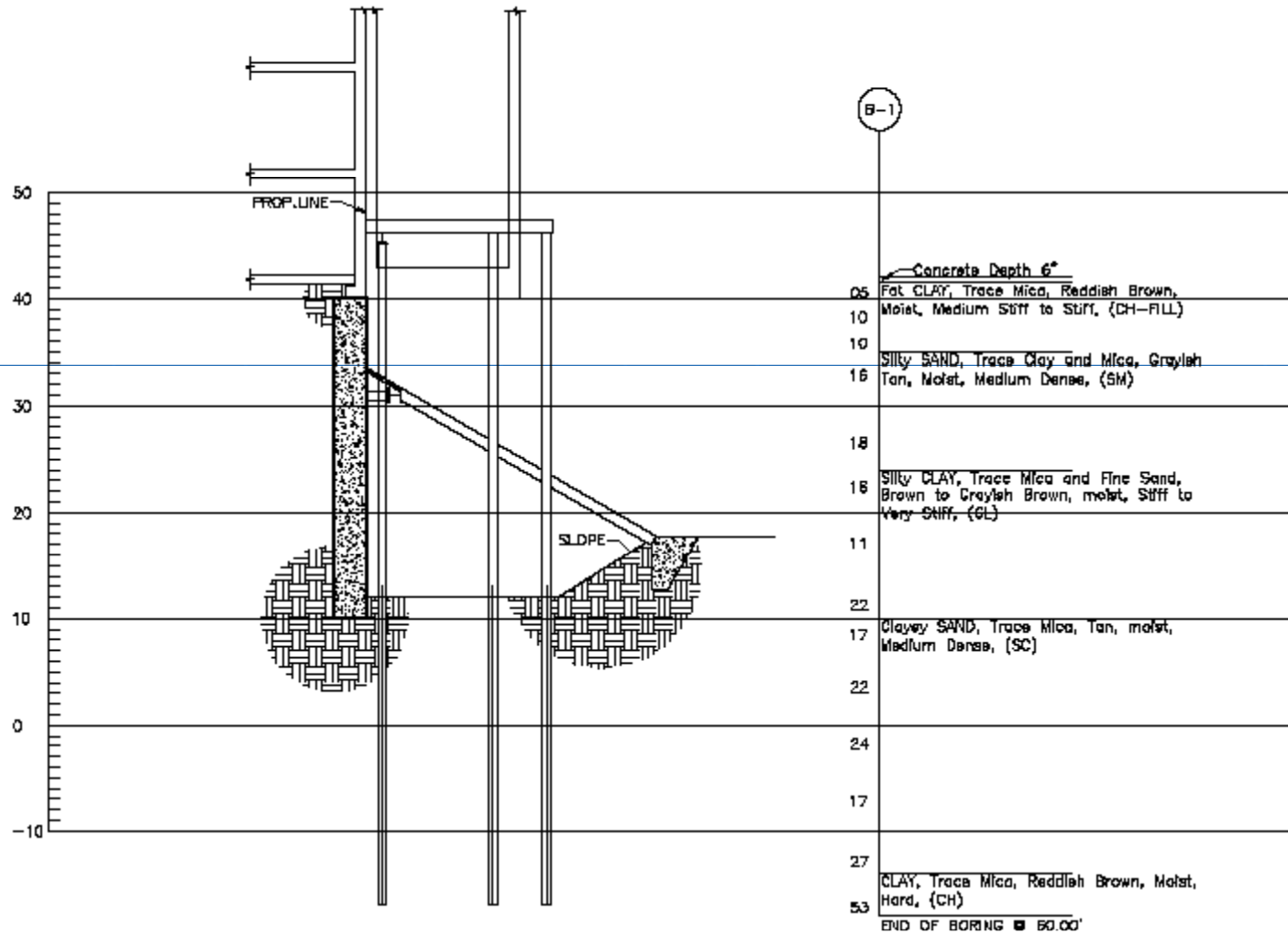

## DESIGN CONSIDERATIONS

- FHWA, AISC
- Column Design (Combined Axial and Bending) as well as an Axial Micropile Design (assumed elastic deflection of 0.1" or 2.5 mm)
- design load of 318 KN (71.5 kips) (4 MP supported typ. 1 building column = 286 kips)
- total micropile length is 19 meter (or 62ft)
- micropile casing diameter of 24.45 centimeters (9 5/8")
- micropile casing wall thickness of 1.38 centimeter (0.545")
- (40ft) 12.2 meter casing per micropile
- bonded length of (22 ft) 6.7 meter, this equals 3.25 kips/LF or 90 psi Grout-to-Ground Bond strength
- (30ft) 9.2 meter of #11 bar in the bonded length with an overlap of 2.4 m (8ft) to the casing
- Medium Dense Clayey Sand for the overall depth of the bonded length of all micropiles with blow counts of 17 to 24

# Overhead Limitation

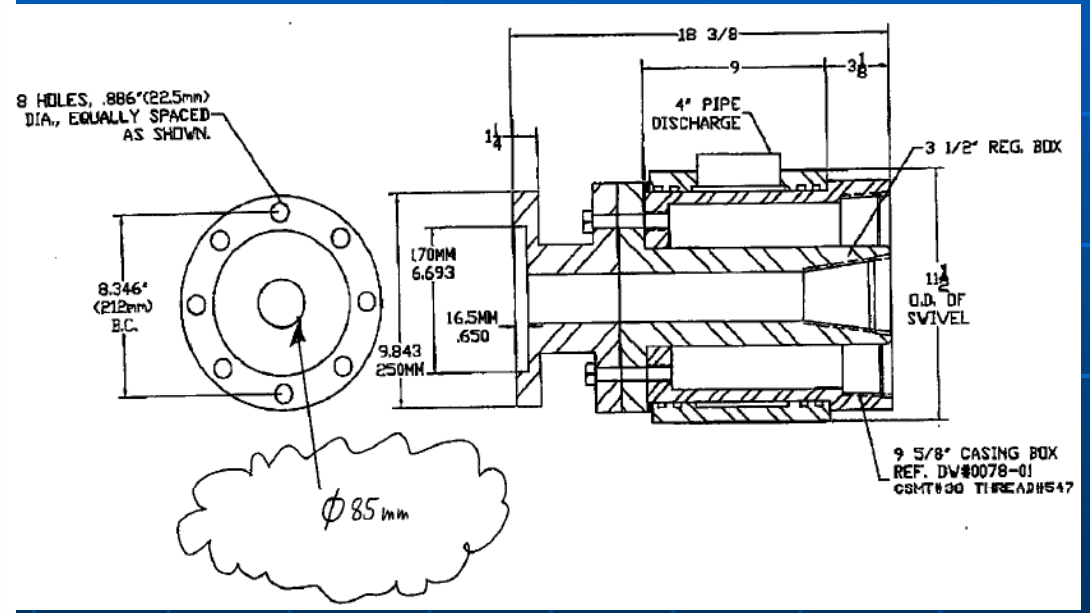
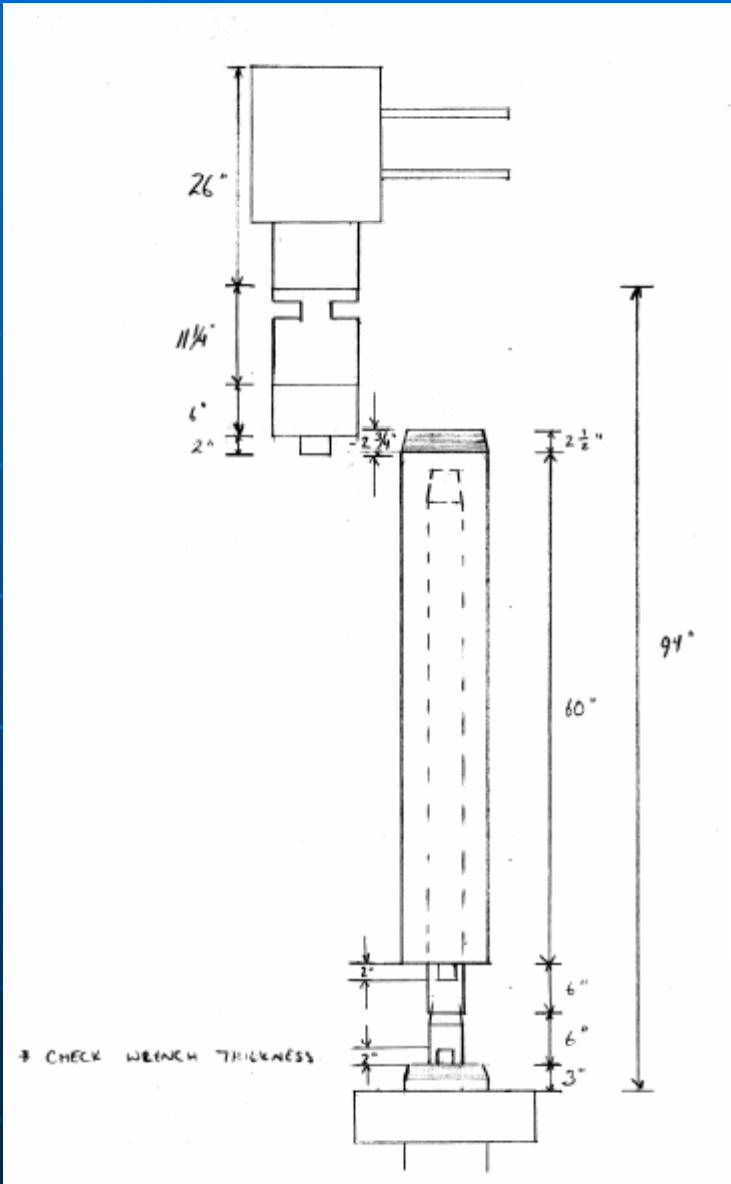



## The Installation



- 5 FT casing (Skyline Steel)
- Water/cement ratio of 0.45-0.5 (5 gallons of water/94LB cement bag)
- Gravity grout only
- Mixed drilling method (air and water)
- Starter casing with teeth and Drag-Bit
- Klemm 702 and Hutte 202 (diesel/electric)
- Both are Single-Head-Drills



# Micropile Test

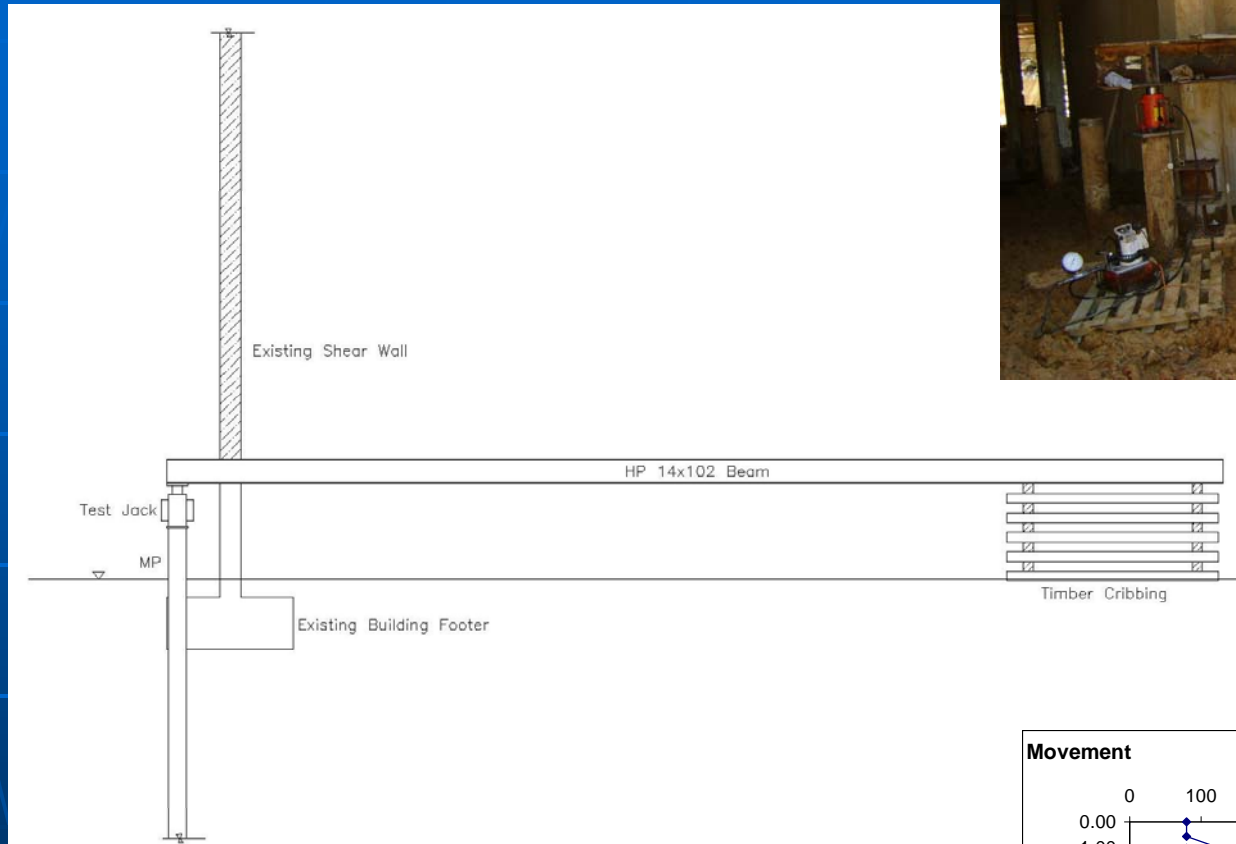

- Load cycles up to 2 times the design load
- A Micropile shall be considered acceptable if it meets or exceeds the following criteria:
  - Creep does not exceed 0.05" (1.27mm) between the 1 and 10-minute readings or 0.1 inches between the 6 and 60-minute (or the last time held) readings. The creep rate shall be linear or decreasing during the creep test load hold period.
  - The Micropile develops maximum test load without continuous loss of jack pressure.

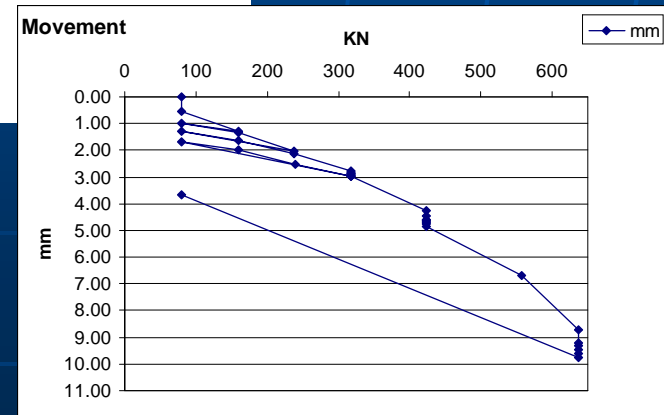

**Schnabel**

FOUNDATION COMPANY





**Schnabel**

FOUNDATION COMPANY



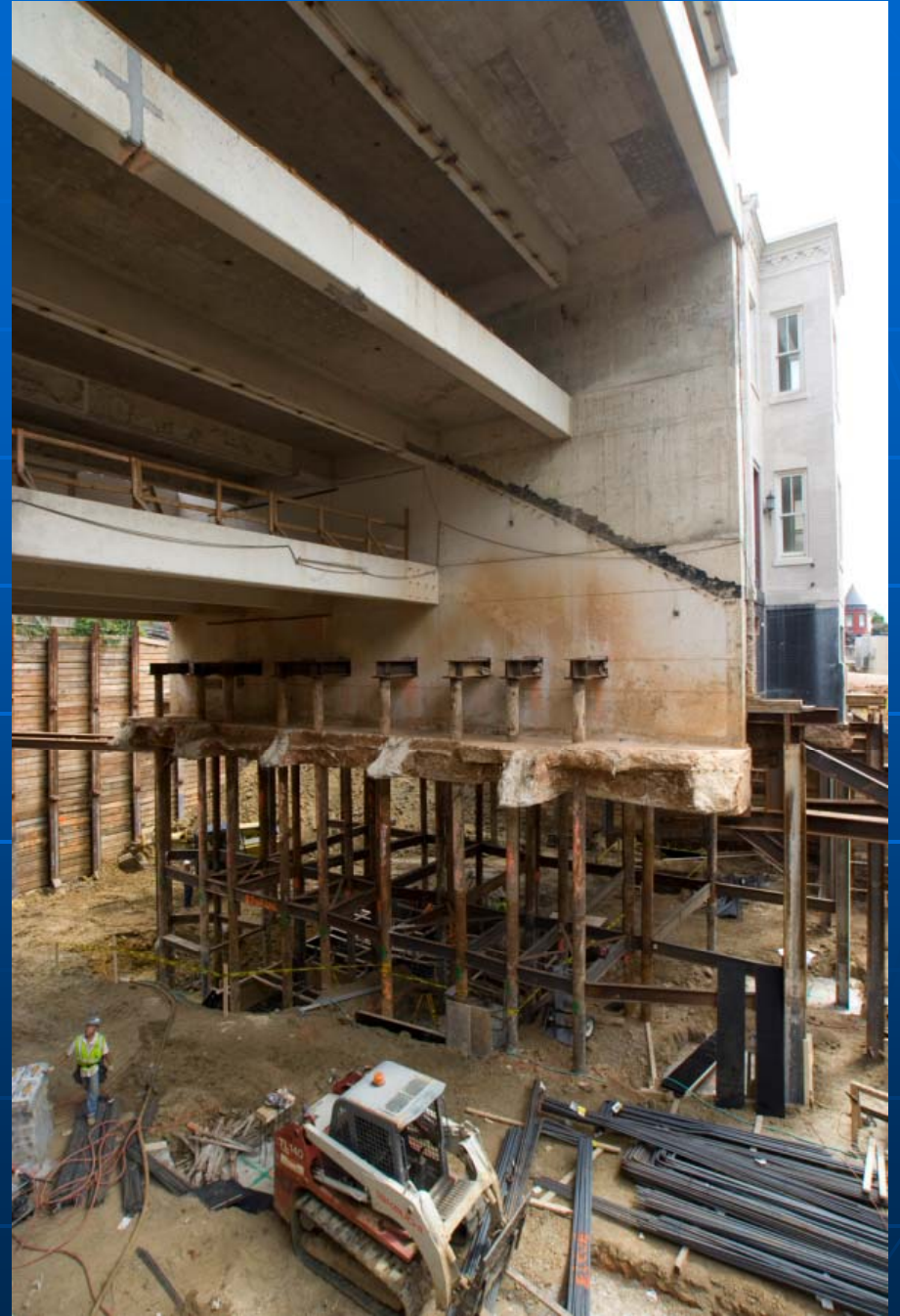

Thanks for your attention

